

# **A Multi-purpose Microwave Signal Source**

**By Steve Kostro, N2CEI**

## **PREFACE**

There are many reasons the upper microwave bands are underutilized. One of them is basic. It is the accuracy and stability of microwave frequency sources. You may have tried one or two bands above 23 cm and found this out for yourself by spending more time spinning the VFO dial than you thought possible to make a single local contact. In addition, if you are a circuit builder, you found it to be a relentless challenge. Many oscillators later, you are still tuning up and down the band, chasing that easy contact and the thought of moving up to the next higher band is making you wonder where the fun part of the hobby has gone! Then again, you may not have the room in your rover rig for additional bands if it requires a back seat of test gear to verify your frequency of operation. Simply said, if all of the microwave gear you have ever used were more "frequency reliable", you would spend more time on the microwave bands.

This paper will discuss ways of improving the equipment you have in use or provide suggestions on how to revitalize the equipment that is not in use because of frequency problems. It will also provide ideas to reduce the size of portable equipment and simplify existing and future designs of microwave transverters. This paper will also discuss operating techniques that will aid you and your existing equipment in making contacts that are more pleasurable based on better frequency accuracy.

## **THE MULTI-PURPOSE MICROWAVE SIGNAL SOURCE**

The past 8-10 years has produced many designs, some simple, some complex, that improves the accuracy and stability of existing microwave oscillators or are stand-alone circuits that provide a synthesized microwave signal. There are pros and cons of all of these circuits but they do have something in common. The designs presume an accurate frequency standard or "Clock" is supplied by available commercial surplus GPS equipment that in turn provides a phased locked 10 MHz signal or a raw 1 PPS (pulse per second) signal. The use of GPS referenced circuits assure both stations in QSO will be on the same exact frequency. The fact that GPS accuracy is now available economically to anybody should stimulate anyone that is interested in frequency accuracy and stability into using a new microwave frequency source

This new multi-frequency microwave signal source is called the ApoLO-32 or A-32 for short. This circuit is designed by Steve Hicks, N5AC. It is a pre-programmed synthesizer that is available assembled and tested only. The first version was supplied with 32 pre-programmed frequencies, (hence the name) but the latest C4 revision provides 50 frequencies that may be utilized in many makes of microwave transverters. The output power levels of the A-32 signals are pre-set to accommodate most multiplier circuits used in transverters through 24 GHz. The A-32 also provides selected standard microwave band markers for receiver detection and calibration. An external 10 MHz source (GPS or other) is required to provide best frequency accuracy. An internal 10 MHz source option is available for the A-32 providing a compact circuit but has less accuracy than a quality external 10 MHz. source. There will be more discussion on this subject later. The published list of frequencies are shown next.

Band	IF	Frequency	REV	Predicted PN, dBc/Hz @ 1 kHz
2304	144	1080		-81
"	145	1079.5		-79
"	147	1078.5		-79
2320	144	1088		-81
2424	144	1140		-81
3456	144	1104		-81
"	145	1103.6667		-78
"	147	1103		-81
3400	144	1085.3333		-80
"	145	1085		-81
5760	144	1123.2		-78
"	145	1123		-81
"	147	1122.6		-76
"	432	1065.6		-78
"	435	1065		-81
10368	144	1136		-81
"	145	1135.8889		-74
"	147	1135.6667		-78
"	432	1104		-81
"	435	1103.6667		-78
"	1296	1008		-81
24192	144	1002		-81
"	147	1001.875		-80
"	432	990		-81
"	435	989.875		-75
24048	144	996		-81
"	147	995.875		-75
"	432	984		-81
"	435	983.875		-75
903.1	WSS	903.1		-74
915	WSS	915		-81
1296.1	WSS	1296.1		-74
1152.02	WSS	1152.022		-74
2401	WSS	1200.5		-79
902.1	WSS	902.1	C2	-74
1275	WSS	1275	C2	-81
1420	WSS	1420	C2	-81
1296	144	1152	C2	-81
2400	144	1128	C2	-81
5760	1296	1116	C2	-81
1296	28	1268	C2	-81
1296	145	1151	C3	-81
2300	145	1077.5	C3	-79
2300	144	1078	C3	-81
2400	145	1127.5	C3	-81
10368	145	1022.3	C3	-74
10368	144	1022.4	C3	-78
1296	147	1149	C3	-81
1296	29	1267	C3	-81
1420	144	1276	C3	-81
10368WDG	144	1278	C4	-81

The list shows what band the frequency are programmed for along with its “IF” frequency use. Frequency selection is achieved by selecting and connecting a set of pads, 0-7 to ground. The chart also shows the predicted Phase noise in dB below the output signal carrier, 1 KHz away from the output signal carrier. Actual measured phase noise performance has always been better than the predicted. The Phase Noise of any frequency source can and may contribute noise to a microwave receiver system. Hard numbers stating what level of phase noise degrades actual receiver performance have never been published for amateur use. To this date, we have not had any negative feedback concerning phase noise and receiver performance related to the phase noise from the A-32 masking weak microwave signals.

My personal experience in participating in over 300 portable QSO’s with an A-32 installed and used in various microwave transverters on various bands, has only netted the expected “Strong Signal” distortion that is similar to the overloading of early production solid state VHF transceivers. Since most contacts are “weak signals” in nature and the slightly distorted signals are the strong ones, it did not affect my operating style. What I did find during portable operation was the fact of knowing that both sides of the QSO are on the same frequency, makes a difficult contact easier when the only concern is antenna aiming.

### **THE MANY USES OF THE A-32**

The most basic implementation of the A-32 is as a Weak Signal Source for the microwave bands 902 and up. It requires no changes to your existing equipment to improve your stations capabilities. The A-32 is programmed with the weak signal calling frequencies on 902/903 and 1296 to be used a band markers. The band markers on 2304 and up are derived by multiplying the 1152.022472MHz signal. It will produce the final frequencies as shown on the chart below.

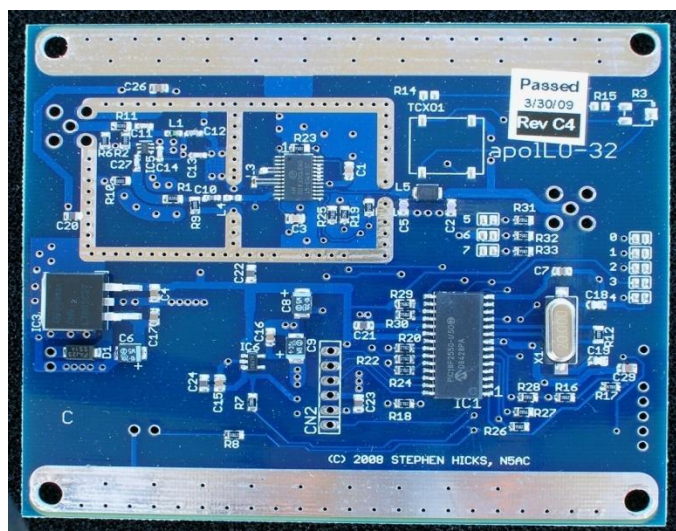

<b>Band</b>	<b>Multiplier</b>	<b>WSSA Output Frequency and Output Power</b>	<b>Frequency and minimum Signal level</b>
33cm	1	902.100 MHz. +5dBm	902.100 MHz. @ +5dBm
33cm	1	903.100 MHz. +5dBm	903.100 MHz. @ +5dBm
33cm	1	915.000Mhz +5dBm	915.000 MHz. @ +5dBm
23cm	1	1275.000 MHz. +5dBm	1275.000MHz. @ +5dBm
23cm	1	1296.100 MHz. +5dBm	1296.100 MHz. @ +5dBm
21cm	1	1420.000 MHz. +5dBm	1420.000 MHz. @ +5dBm
13cm	2	1152.022472 MHz. +5 dBm	2304.044944 @ -17dBm
12cm	2	1200.500 MHz. +5dBm	2401.000 @ -20dBm
9cm	3	1152.022472 MHz. +5 dBm	3456.067416 @ -27dBm
5cm	5	1152.022472 MHz. +5 dBm	5760.112360 @ -43dBm
3cm	9	1152.022472 MHz. +5 dBm	10368.202248 @ -67dBm

A simple hot carrier diode across the output of the A-32 will produce harmonics at levels easily heard in any microwave converter. As a side note, 1152.000 MHz is also available to multiply up indicating the “.000” frequency on all of the bands 2304 and up. It is suggested not to use 1152.000 because it may get confused with the LO of a 1296 transverter or the harmonics generated from 144.000 MHz. Having an offset on 1152 (1152.022472 MHz.) positively identifies the desired usable signal.

If you have never used a weak signal source for a band marker before, follow this simple procedure. With the A-32 connected correctly and set for 1152.022472, it generates a signal for all practical purposes on 2304.045 MHz. (2304.044944). You tune your 2304 system to the signal and instantly calibrate by determining the difference between your VFO and the A-32 signal in KHz. You may also note if your 2304 RX is drifting and which way, up or down. Then, go to the desired contact frequency or suggest to the other station to move to 2304.045 MHz. With an external 10 MHz source on the A-32, you can switch the A-32 signal off to make the contact and switch it back on to recalibrate if required because as long as your 10 MHz. source is stable (GPS Locked and powered separately) the A-32 will lock up on the exact frequency every time providing a accurate frequency standard. This will work with the higher microwave bands in the same fashion. Just do the math. Depending on the quality of the hot carrier diode used, there may be a usable signal on 24 GHz. (24,192.471912 or the practical frequency of 24,192.472). A perfect situation is both stations having the A-32 as a signal source and a GPS derived 10 MHz. sources.

A final use for the A-32 as a weak signal source is to use it as a RX level calibrator. With a simple band pass filter and then calibrated against a known level, a pre-determined receive level is at hand to test all microwave band receivers.

*The simplest implementation of the A-32* is to replace each base local oscillator in each transverter. Of course, this is the simplest, not the most cost effective. If it is a DEMI transverter, just pop the top and replace the MICRO-LO with the A-32. The A-32 is a drop in fit as shown. The existing power wire and RF coax are re-used. The only other connections that need to be completed are for the 10 MHz input and the Lock indication LED. If you desire multiple frequency use out of the transverter such as 2304 and 2320, a switch may be installed.

There is a retrofit option offered that has all of the “extras” required including spare coax in case the original is broken. The advantage of choosing to install one A-32 in each transverter is that it is the simplest and cleanest approach. The only extra cabling would be interconnecting the 10 MHz. ports on all of your transverters. If you only have one transverter such as a 10 GHz unit,

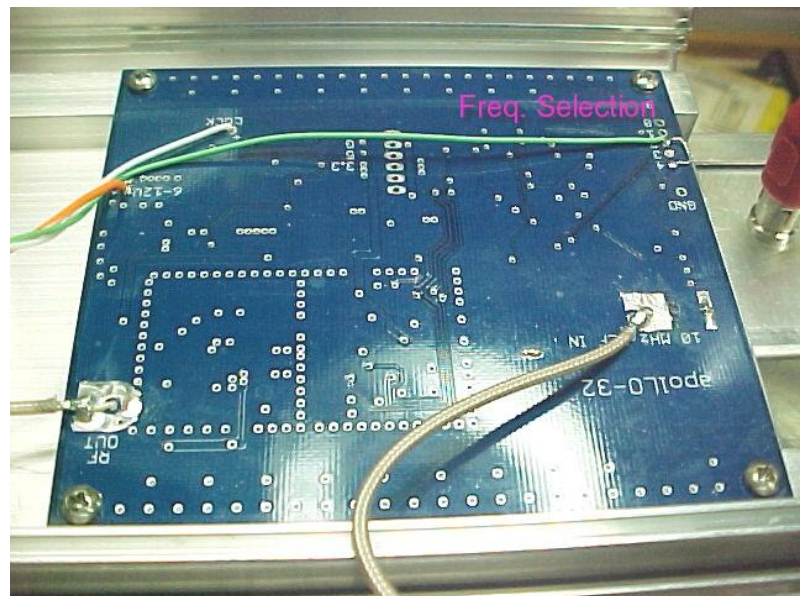

there is no advantage to install the A-32 external from the transverter. If you have multiple transverters, you may choose to retrofit one band at a time. Start with the worst offender first. Once you see how simple it is and how it performs you may want to try to use the A-32 that is installed in the one transverter as a Weak Signal source for the others or devise a switching scheme to provide the LO signal for an additional transverter. A switching scheme isn't that complicated with just a little "HAM" ingenuity.

The A-32 may be implemented as a retrofit in many other transverters. How many older design transverters have been retired because their LO's were un-reliable? Why not revive an old transverter with a state of the art microwave signal source. Look at this G3WDG 10 GHz transverter. This was my first 10 GHz transverter. I have not used it since 1991-92. The local oscillator has caused many a stressful moment in my hobby. Therefore, the transverter was placed aside for many years. The Local Oscillator is now

missing (or trashed) after being rebuilt and repaired many times but the "RF" circuits were intact and still quite useable! The early Microwave transverters were designed with strings of expensive GaAs FETs, meticulous coil winding, and specific and precise filtering. So, with a few component upgrades, (replace adjustable bias components,

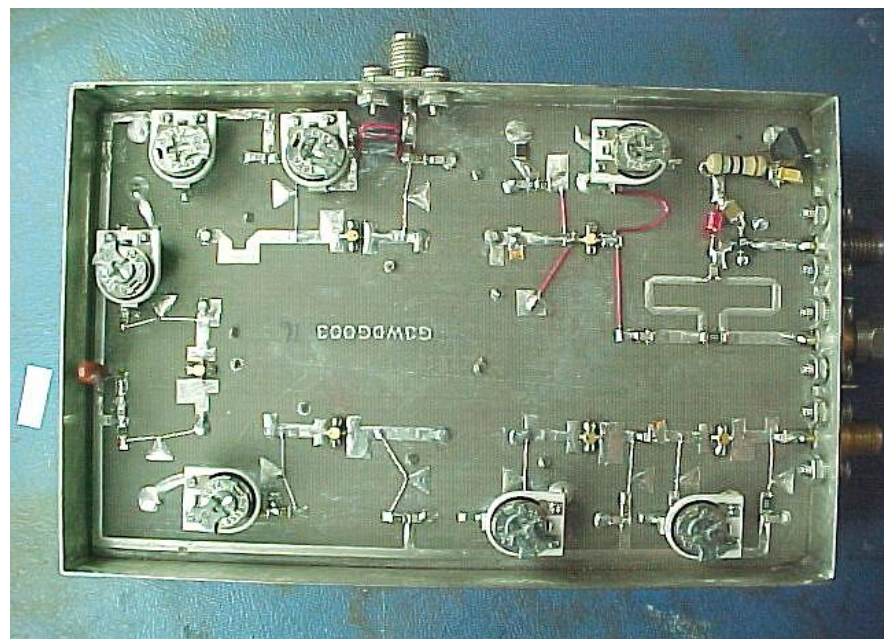

replace broken chip capacitors) my G3WDG transverter came back to life. The RF works of most of the first microwave transverter products are sound and as good as a modern day transverter. Yes, they may have a few obsolete components but except for the local oscillators, they are still useable today. Now, the oscillator circuit can be replaced with a synthesizer. Some of the following details in modifying the G3WDG design could be implemented in other makes and models of transverters on other bands. This modification is presented for an example.

The G3WDG 10 GHz design, was based on a 100 MHz oscillator (106.5 MHz I believe) and multiplied, filtered, and amplified to produce a +10dBm signal at 2556 MHz. The details of the LO circuit are spared here because we are replacing it. The point is, a +7 to +13 dBm 2556 MHz. signal was supplied to the transmit module where the LO power was amplified and split to deliver a LO signal to the RX and TX converters separately. Also note that the advantage of upgrading this unit is that the LO was a separate self-contained module as are the TX and RX converters. See figure 1.



The engineering problem now becomes utilizing a 1 GHz synthesizer to produce a 2 GHz signal within the 10 GHz transverter. Well, we discussed it in the WSS portion of this paper, almost. One of the A-32's programmed frequencies, 1278 MHz, operates at  $\frac{1}{2}$  of the required frequency of the G3WDG 10 GHz. transverter. A simple multiplier would work but would entail an extra stage between the transverter and the A-32 synthesizer, external to the enclosure. This extra stage could be incorporated in the same enclosure that houses the A-32 but again, the problem is the extra circuitry.

A further experiment was then performed. The transmit converter has a buffer amp before it is split for both converters. If this buffer could operate as a doubler-amplifier stage, it would solve the problem. The buffer is a standard MSA1104 (MAV-11) and did not have the gain required at 2556. (Less than 6 dB) It was a wonderful stable buffer amp, but it did not double the frequency at a level high enough unless you added an additional amplifier.

I decided to substitute the MAV-11 with a different MMIC. I chose the ERA-5 because of its high gain and higher output power. My experience has also shown me that a second harmonic level is an easy task for this MMIC. The bias resistor in the circuit was changed to accommodate the ERA-5 and I added a +9 VDC voltage regulator to keep the voltage steady. It was a drop in, test, ready to operate type of operation. See figure 3. Below for the modified circuit

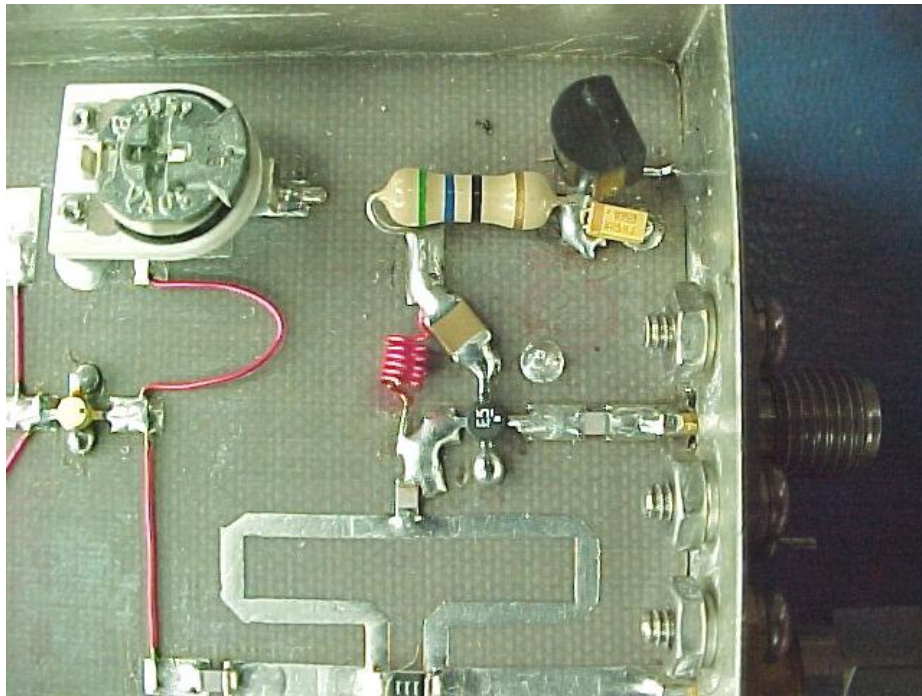

**Figure 3 The 2556 Multiplier Stage**

The Wilkerson power divider after the new multiplier stage helps attenuate the fundamental 1278 MHz. signal. It is designed to operate on 2556 MHz. All other harmonics are filtered out of the 10 GHz TX and RX stages and the final levels of harmonics are similar to the numbers originally specified in the design. On the receive side, the 2556 MHz signal, after the power divider is amplified, then filtered before it

enters the mixer. I attempted to re-tune the filters in both TX and RX modules for better performance but did not yield any noticeable improvement.

The A-32 in this case is a simple and quick fix to produce a frequency stable and accurate 10 GHz transverter ready for action. This was only one example of how to upgrade a labeled "Obsolete" transverter by today's standards and what can be done with the new A-32 synthesizer. Many "older design" transverters can benefit from an upgrade as described here. If an older transverter has a sound RF section that may only need the help of a LNA or power amplifier, the A-32 can provide the stable frequency source to get it back on the air making enjoyable contacts again.

The economic implementation of a A-32 is to incorporate one A-32 synthesizer with multiple transverters. Your system may already have a multiband IF switch to select individual transverters connected to your single 2M transceiver. This switch may also incorporate the PTT signal lines. What if this same switch chose the operation frequency of the A-32 and directed its output to the correct transverter. Using the A-32, this could be implemented with 7 microwave transverters 900 MHz. through 24 GHz. resulting in a economic savings.

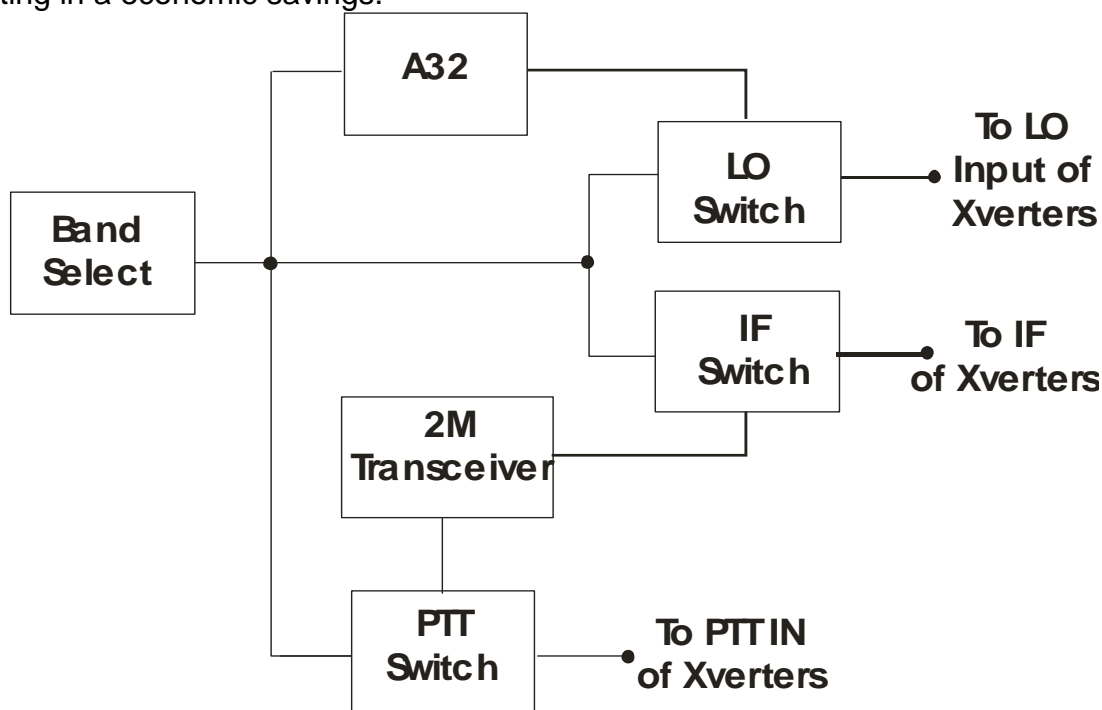

**Figure 4**

A multi-poled wafer switch or computer interface could control the actual band switching. The only other item added to your system would be a multiple position 1 GHz RF switch and a single A-32. Since the RF output level of the A-32 is around +5dBm, you could build a single pole multiple throw PIN diode switch to switch the A-32 signals to the LO inputs of the transverters. In any case, you would eliminate all oscillators in the existing transverters. This would eliminate warm up times and stability problems. It will also allow you to shut down the transverters not in use to save battery power during portable operation. In fact, installing an extra pole of switching to power the transverter

“ON” when that band is activated could be utilized to further save battery power. There is no need to keep the transverter warm when using an A-32 synthesizer.

The amount of A-32 frequencies (50 max for now) and transverters are only limited by the design requirements of your system and the type of operation you prefer. It is possible with one A-32 and the correct configuration of 7 transverters, one could operate on 902, 903, 1296, 2304, 2320, 3456, 3400, 5760, 10368, 24,192 MHz and any other portion of those bands by simply flipping a switch or depressing a band up/down key on your computer. If this sounds interesting, what is stopping you? Well, if you are a RF circuit builder, maybe you should carry the thought process a bit further and consider the future in transverter design!

The future implementation of the A-32 synthesizer or a future revision of the A-32 may be something like shown in the block diagram in Figure 5. A single A-32 synthesizer and a single mixer that operates from 900 MHz through 10 GHz. are the main features of this future transverter. Between the A-32 and mixer is a pair of single pole, 6-position PIN diode switches that select the correct multiplier stages (not required for 900 and 1296 bands) as the frequency selection of the A-32 is made. The “IF” port configuration of the mixer, once set, would never change as the bands change unless it is desired to change the IF frequencies such as 28 MHz for 1296 and 432 MHz for 10368 MHz as an example.

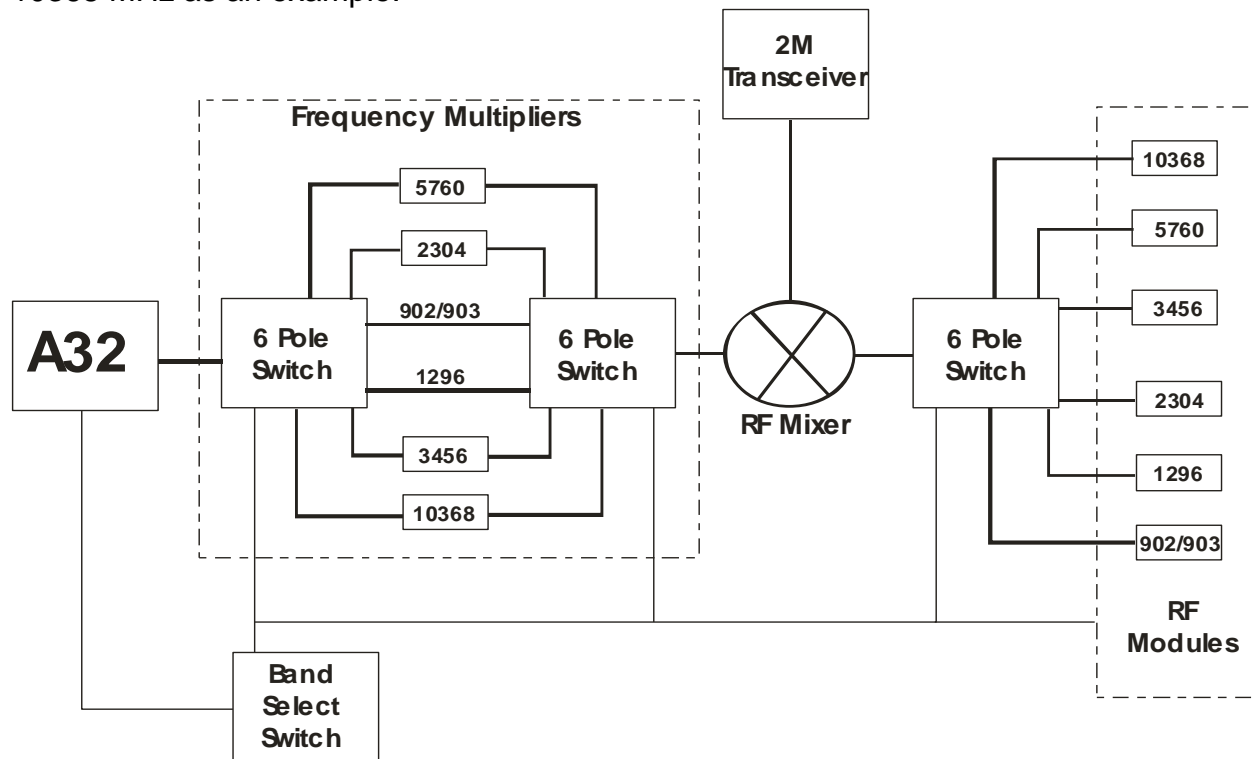

**Figure 5.**

A third 6-position PIN diode switch is utilized on the RF port of the mixer to switch the low-level band dependant TX/RX RF Amplifier/Filter sections. A simple 6-band low-level transverter of 10 mW and respectable noise figure could be designed to fit into a small single enclosure. This would then make it possible for the operator to add higher-

powered (1-10 watts) /lower noise figure TX/RX/Filtered modules one at a time or design and build their own as the operator saw fit to increase their operating fun and as economics allowed them. Higher-level single band modules could be provided as stand-alone or “plug-in” RF units if an enclosure was properly designed.

For now, there are a few items preventing this from happening. An economical wide band mixer covering 900 MHz. – 10 GHz. is not yet available. (2-10 GHz. 750 MHz – 5 GHz. are available) It may be possible to stretch the frequency limits of some mixers on the market now but I have not had a chance to try any as of yet. Designing the frequency multiplier/filter circuits for 4 bands (remember two bands are bypassed) on one circuit board should be a simple task. Each circuit would only be powered up when that band is switched on. This also assumes that the A-32 will operate in a wider range (750 – 1152 MHz) than now specified. Testing has been done to provide the A-32 for 33 cm operation and it will not be a problem in the near future. Bottom line is simplifying the frequency source will change the future of transverter design.

10 MHz frequency standards need to be mentioned. A good standard is the heart of any accurate frequency measurement and generation setup. The more accurate and stable the 10 MHz source used with the A-32, the more accurate its generated signal will be. This paper and presentation assumed a GPS type of source is used. The fact is that simple crystal derived 10 MHz. sources are being used for portable and home use. Most are TCXO's and require only a regulated power supply and a thermal protected environment to provide accurate and stable performance after being calibrated against a GPS or Rubidium type source. 1 Hz of frequency resolution is not required to make enjoyable contacts on the microwave bands. Simple economical and quite portable sources are available on the surplus markets that require a minimal amount of care to provide accuracy and stability within 300-400 Hz on the 10 GHz band. Many can be optimized to perform better with very little effort. So, do not think you need a \$250-\$500 dollar GPS unit to start to have some fun with an A-32 synthesizer.

## **CONCLUSION**

With the A-32, there is no more adding a second oscillator circuit to a transverter if you desire to operate on a different portion of the band. There is no more ordering that special order crystal to get your second oscillator operating. There is no more “Tweaking” and allowing the Crystal to age to eliminate frequency drift. There is no need for warm up time. It is instant on if your 10 MHz source is ready and locked. With simple switching, a single A-32 can have multiple uses supplying multiple transverters or it simply fits in a DEMI transverter enclosure and/or operates as a standalone weak signal source for receiver detection and calibration.

I hope after reading this paper along with seeing my presentation at this conference, I have stimulated you into either blowing the dust off your old transverter OR- at least made you think about simplifying your existing microwave systems. AND- If anything, if frequency stability and accuracy woes have kept you off the microwave bands, you now have a simple alternative. I hope you try the A-32.

Have fun and catch you on the bands!  
73, Steve, N2CEI